

Charge Plus DC-DC Timer Switches

Australian designed and built, Lucidity Australia's Range of Timer Light Switches are specifically designed for the rigorous demands of the Australian Transport Industry.

There is a Timer Switch suitable for the entire scope of truck trailer combinations found in Australia and applications such as interior lamps in refrigerated vans is but one example. All models specifically overcome known industry pitfalls with intelligent design and years of research being applied specifically to create a product that has no equal in the market.

Features such as:

- Diecast Aluminium Housing
- Low Battery Input Protection
- Overcurrent protection
- One Touch Timer Programming

All play a major role in ensuring our products outperform and outlast the competition.

Additional Features.

Most importantly, a Refrigerated Van should perform its main duty: to deliver produce at the correct temperature. Many switch products on the market, if left switched on, will flatten a refrigeration unit's battery. This leaves the refrigeration unit inoperable.

If the correct switch is fitted for the application, our timer switch will never flatten your battery.

If a switch is selected with programmable time options, the switch is programmable from the on/off button. Simply press and hold the on/off button to select the desired time duration. Alternatively, the switch may be programmed to be a simple on/off switch with no time lapse. Even if the timer switch is left on, it will not allow the refrigeration unit's battery to go flat. The timer switch will shut down when the voltage threshold to start the refrigeration unit is reached.

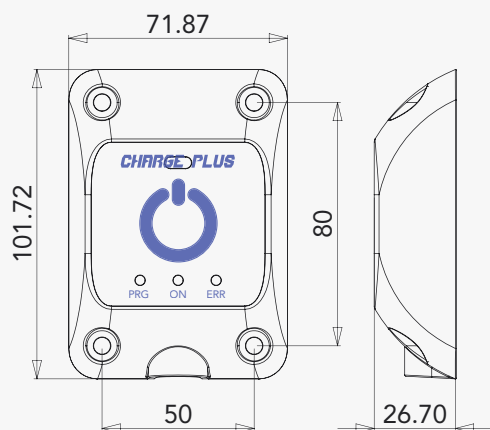

Key Features		TIMER SWITCH MODELS			
		3970009	3970018	3970019	3970020
INPUT VOLTAGE	12 Volts DC	✓	✓	✓	✓
	24 Volts DC		✓	✓	
	From Lighting Reducer			✓	
	Input Over-voltage Protection	✓			✓
SELECTABLE RUN TIMES	Non-timed — Press to Turn On/Off	✓	✓	✓	
	5 minute				✓
	30 minute	✓	✓	✓	
	60 minute	✓	✓	✓	
	90 minute	✓	✓	✓	
Over Current Protected Output		✓	✓		✓
Short Circuit Protected Output		✓	✓		✓
Low Input Battery Protection (protects input battery against over-charging)		✓			✓
Remote Switch Input Provision		✓	✓	✓	✓
"PRG" LED COLOUR	RED	✓	✓		✓
	YELLOW			✓	
"ON" LED COLOUR	RED	✓			✓
	YELLOW		✓	✓	
"ERR" LED COLOUR	RED	✓	✓	✓	✓
	YELLOW				
Diecast Aluminium Housing		✓	✓	✓	
Encapsulated Electronics		✓	✓	✓	✓



Optional Switch

Part Number: **3370421**

All Lucidity Timer Switches have an optional remote input trigger which can be connected to our surface-mounted IP69 rated Remote Switch.

This switch is fully water-proof, stainless steel and has NO moving parts. It is ideal for the rigours of the transport industry and ideally designed to fit inside or outside the rear entry doors of a refrigeration van.



Address : 37 Paraweena Drive, Truganina, VIC 3029

Tel: + 61 3 9219 4074

Web: www.lucidityaustralia.com.au